



**EADIPS®**  
**FGR®**

**European Association for  
Ductile Iron Pipe Systems**

**Fachgemeinschaft Guss-Rohrsysteme**

**EADIPS®/FGR® STANDARD**

**2013-06**

<b>Ductile iron pipes, fittings and valves</b>		<b>EADIPS®/FGR® 30</b>
<b>Lengths of bolts for flanged joints</b>		
Rohre, Formstücke und Armaturen aus duktilem Gusseisen		<b>Replaces 2012-02 edition</b>
<b>Schraubenlängen für Flanschverbindungen</b>		
<b>Amendments</b>		
To Normative references		
To Dimensions and limit deviations		
<b>Contents</b>		<b>Page</b>
1.	Scope	2
2.	Normative references	3
3.	Dimensions, limit deviations	4
4.	Material, mechanical properties	5
5.	Surface protection	5
Except where consented to by the European Association for Ductile Iron Pipe Systems · EADIPS® / Fachgemeinschaft Guss-Rohrsysteme (FGR®) e. V., EADIPS®/FGR® standards may only be published or reproduced with their form and content unamended. The consent of the EADIPS®/FGR® is required for the reproduction of an EADIPS®/FGR® standard in any shortened form.		
European Association for Ductile Iron Pipe Systems · EADIPS® / Fachgemeinschaft Guss-Rohrsysteme (FGR®) e. V. Im Leuschnerpark 4 · 64347 Griesheim, Germany · E-Mail: <a href="mailto:info@eadips.org">info@eadips.org</a> · <a href="http://www.eadips.org">www.eadips.org</a>		

## 1. Scope

The bolt length “l” is designed for ductile iron flanged joints of type 21 (integral flange) in accordance with EN 1092-2 for:

- PN 10 to PN 40,
- type B flange facing,
- gasket with metallic insert in accordance with EN 1514-1,
- nut in accordance with EN ISO 4032 and one, two or no washer(s) in accordance with EN ISO 7091.

Where ductile iron flanges are combined with flanges of other materials, different bolt lengths must be considered.

This standard specifies bolt lengths which reliably cover the permitted limit deviations on the components of flanged joints.

This applies even to cases where, in contrast to what is shown in the drawing in section 3, only one washer or no washer is used on each bolt.

## 2. Normative references

EN ISO 898-1

Mechanical properties of fasteners made of carbon steel and alloy steel -  
Part 1: Bolts, screws and studs with specified property classes - Coarse thread and fine pitch thread  
(ISO 898-1:2009);  
2009

EN ISO 4014

Hexagon head bolts - Product grades A and B (ISO 4014:2011);  
2011

EN ISO 4016

Hexagon head bolts - Product grade C (ISO 4016:2011);  
2011

EN ISO 4032

Hexagon nuts, style 1 - Product grades A and B (ISO 4032:1999);  
2000

EN ISO 4034

Hexagon nuts - Product grade C (ISO 4034:1999);  
2000

EN ISO 4042

Fasteners - Electroplated coatings (ISO 4042:1999);  
1999

EN ISO 7091

Plain washers - Normal series, Product grade C (ISO 7091:2000);  
2000

EN 1092-2

Flanges and their joints -  
Circular flanges for pipes, valves, fittings and accessories, PN designated -  
Part 2: Cast iron flanges;  
1997

EN 1514-1

Flanges and their joints -  
Dimensions of gaskets for PN-designated flanges -  
Part 1: Non-metallic flat gaskets with or without inserts;  
1997

EN 20898-2

Mechanical properties of fasteners;  
part 2: nuts with specified proof load values; coarse thread (ISO 898-2:1992);  
1993

### 3. Dimensions, limit deviations

Bolts for flanges – with one washer, two washers or no washer, as desired. Shown below are the EN ISO standards used for designing the bolt length. Where washers and nuts complying with other standards are used, the resulting bolt lengths may be different.

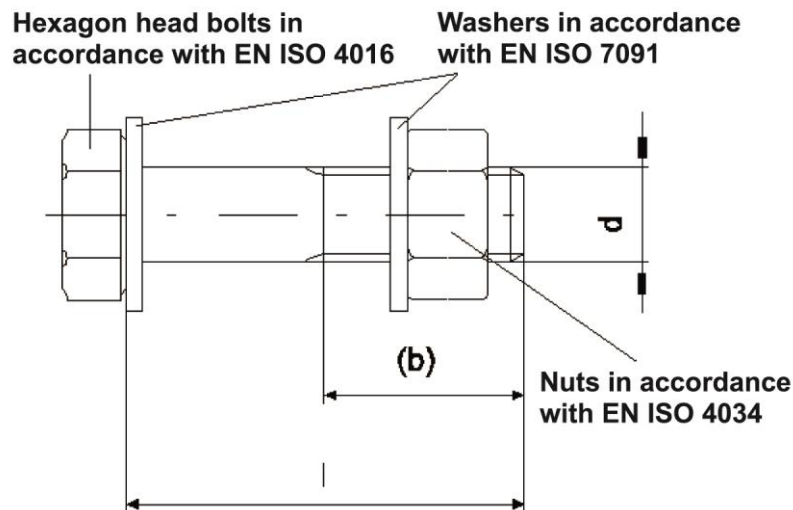

Dimensions in mm

DN	PN 10			PN 16			PN 25			PN 40							
	d	l	(b)	d	l	(b)	d	l	(b)	d	l	(b)					
80	M 16	80	38	M 16	80	38	M 16	80	38	M 16	80	38					
100			48			48			48			M 20	48	M 20	48		
125			M 20			90	48	M 20	90	57	M 24	90	56	M 24	90	54	
150	60	60		60	M 27											110	60
200	66	66		66	M 30											110	66
250	M 24	100	57	M 24	100	57	M 27	110	60	M 30	150	78					
300												72	72	72	M 33	150	72
350												78	78	78	M 33	150	78
400	M 24	100	57	M 27	110	60	M 33	130	78	M 36	160	84					
450												90	90	90	M 39	170	90
500												96	96	96	M 39	170	96
600	M 27	110	60	M 33	130	78	M 36	150	84	M 45	190	102					
700												102	102	102	M 45	190	102
800												108	108	108	M 45	190	108
900	M 30	130	72	M 36	160	84	M 45	180	102	M 52	200	116					
1000												116	116	116	M 52	200	116
1200												122	122	122	M 52	200	122
1400	M 33	140	78	M 39	170	90	M 52	200	116	M 56	240	137					
1600												137	137	137	M 56	240	137
1800												143	143	143	M 56	240	143
2000	M 39	160	90	M 45	190	102	M 56	240	137	M 64	270	153					
1600												153	153	153	M 64	270	153
1800												159	159	159	M 64	270	159
2000	165	165	165	M 64	270	165	M 64	290	153								

#### **4. Material, mechanical properties**

Bolts and nuts are to be in accordance with EN ISO 898-1 and EN 20898-2.  
Strength class of at least 4.6.

An alternative is stainless steel in accordance with EN ISO 4014 and EN ISO 4032.

#### **5. Surface protection**

Bolts, nuts and washers are to have at least an electroplated zinc coating in accordance with EN ISO 4042.